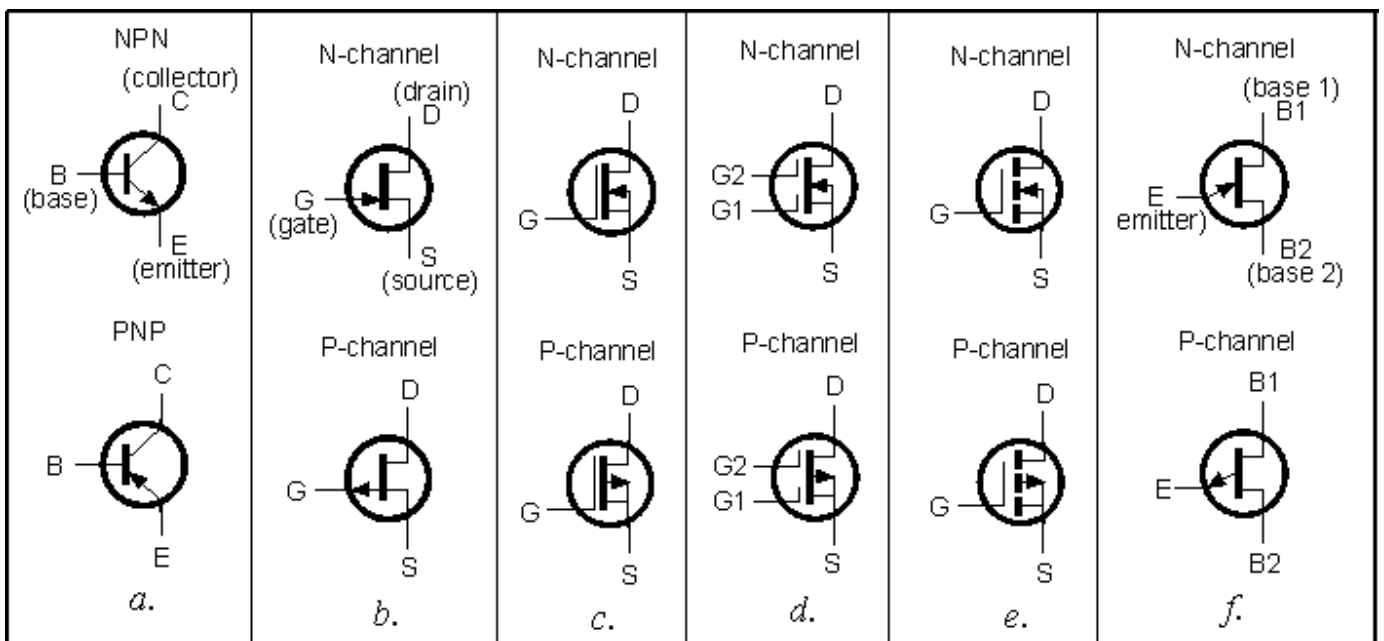

**Fig. 4.1: Different transistors**



**Fig. 4.2: Transistor symbols: a - bipolar, b - FET, c - MOSFET, d - dual gate MOSFET, e - inductive channel MOSFET, f - single connection transistor**

The second letter in transistor's marking describes its primary use:

C - low and medium power LF transistor,

D - high power LF transistor,

F - low power HF transistor,

G - other transistors,

L - high power HF transistors,

P - photo transistor,

S - switch transistor,

U - high voltage transistor.

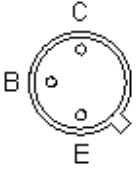
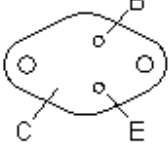
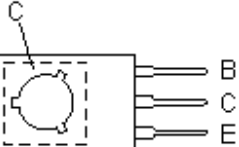
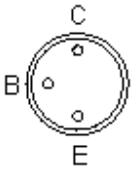
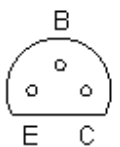
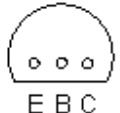
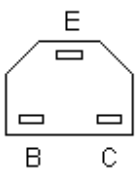
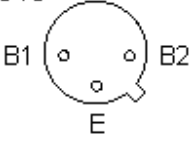
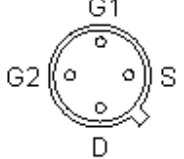
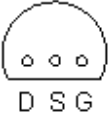
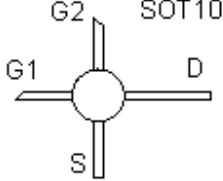
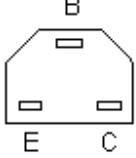
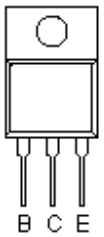
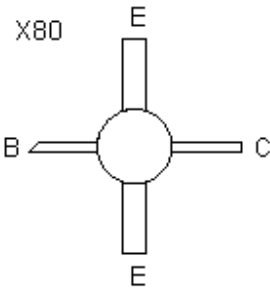
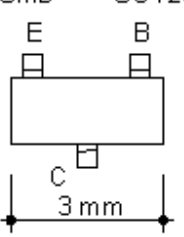
<p>Package TO5, TO18</p>  <p>NPN      PNP</p> <p>BC107      BC177 BC108      BC178 BC109      BC179 BFX84      BC186 BFY50      BC187 2N706      BFX88 2N2369      BCY71 BC286      BC287 2N2904</p>	<p>TO72</p>		<p>TO3 and similar</p>  <p>NPN      PNP</p> <p>2N3055      PNP3055 BDY20      BDX18 BD121      OC26 BD123      AD149 AD161      AD162</p>	
<p>TO126</p>  <p>NPN      PNP</p> <p>BD135      BD136 BD131      BD132 BD437      BD438 BUP41</p>	<p>TO-1</p>  <p>NPN      PNP</p> <p>AC176      AC128 AC187      AC188</p>	<p>X-55</p>  <p>NPN      PNP</p> <p>BC182      BC212 BC183      BC213 BC184      BC214 2N3707      2N3702 2N3710      2N3703</p>	<p>TO92</p>  <p>NPN      PNP</p> <p>BC183L      BC213L BC237B      BC557 BC547      BC307B BC548      2N4402 BC546 2N3705 2N3903</p>	<p>SOT25</p>  <p>NPN</p> <p>BF194 BF195 BF196 BF197</p>
<p>TO18</p>  <p>Unijunction transistor</p> <p>2N2646      2N4870 2N2647      2N4871</p>	<p>TO18</p>  <p>3N140 3N141 40673</p>	<p>TO18</p>  <p>BF256 2N3819 (connection FET)</p>	<p>SOT103</p>  <p>BF960      BF981 BF961      3SK81</p>	<p>SOT25</p>  <p>NPN      PNP</p> <p>BC157      BC147 BC158      BC148 BC159      BC149 BCX35      BCX31</p>
<p>TO220</p>  <p>NPN      PNP</p> <p>BD539      BD540 BD743      BD744 TIP29C      TIP30C BU407      BD244C BUP30      BD240C 2N6099      BD242C BD243C D44C10 BD241C</p>	<p>X80</p>  <p>BFR14      BFR49</p>	<p>SMD      SOT23</p>  <p>NPN      PNP</p> <p>BC846B      BC856B BC847B      BC857B BC848B      BC858B BC849B      BC859B</p>		

Fig. 4.3: Pinouts of some common packages